



## **PANELMAX<sup>®</sup>80**

**MAXimum Strength, MAXimum Durability & Simple Operation**

The **PANELMAX<sup>®</sup>80** is perfect for low to medium cycle applications where high levels of insulation, security and safety is required. The insulating properties of the panels combined with a full perimeter seal provides optimum temperature control reducing energy consumption. Available in a range of economical motorised or manual options.

**AUSTRALIAN MADE  
EUROPEAN DESIGNED**



Standard Track Configuration



Cable Brake Safety Device Standard

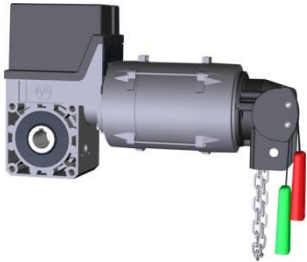

GFA Drive System



Double Glazed Windows

## Technical Datasheet – PANELMAX®80

Application	External/Internal	Standard
Dimension	Max width	6000mm
	Max height	6000mm
Opening/Closing		
Speed	Up to	0.18 mtr/sec
Door Panel	Insulated 80mm Polyurethane panel	Standard
Door Panel		
Colour	RAL 9002 (Surfmist)	Standard
Drive System		
	Motorised	Optional
	3 Phase/415 volt	Standard
Power Supply		Optional (size dependant)
	Single Phase/240 volt	
	Spring and Cable Brake Safety Device	Standard
Safety	Door-line PE Safety Beam/Light Curtain	Optional
	Auto-reversing Optical Safety Edge	Optional
	Emergency Stop Button	Optional
Thermal Properties	U = 0.51 / R = 1.96	Acoustic Properties 25 dB
	U = 0.26 / R = 3.85	38 dB
		40mm Panel
		80mm Panel
Wind Load Rating	Gusts > 120klm/hr (Class 3)	Standard

### Perimeter Seal Features



### Track Configuration Options

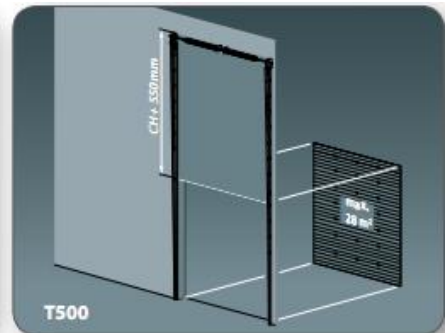
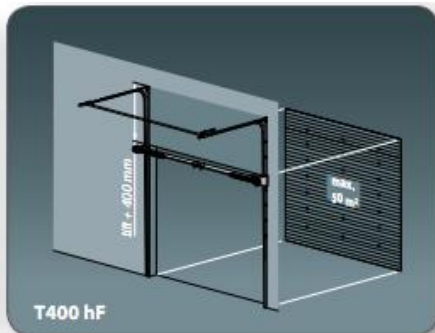
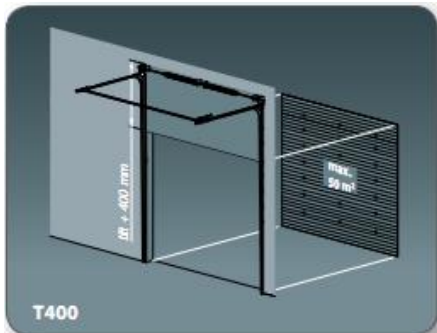

MAX Door Solutions Pty. Ltd.

P: 1300 793 378

[sales@maxdoors.com.au](mailto:sales@maxdoors.com.au)

56 Export Drive, Molendinar, QLD 4214  
PO Box 777, Biggera Waters, QLD, 4216

[www.maxdoors.com.au](http://www.maxdoors.com.au)